

版本 REV.	日期 DATE	ECN NO.	变更内容 DESCRIPTION	制图 DRAWN

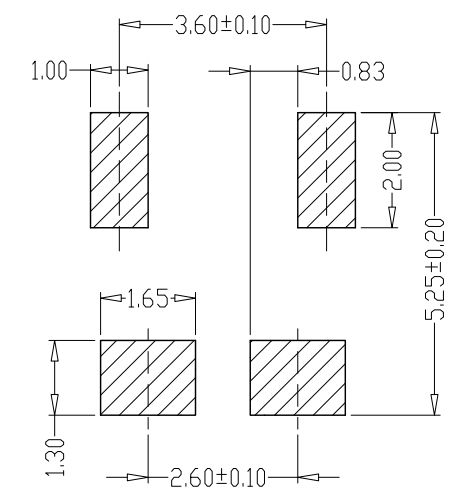

PCB LAYOUT

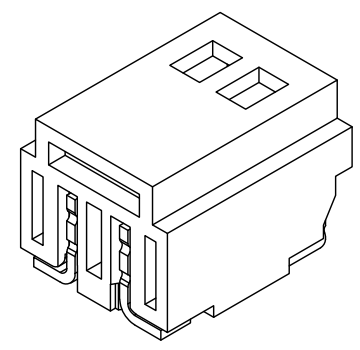
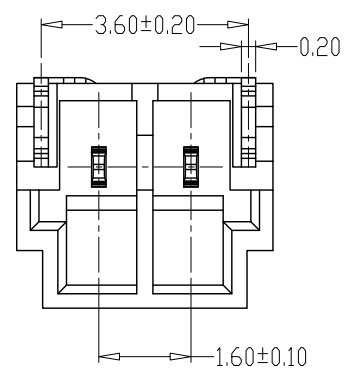
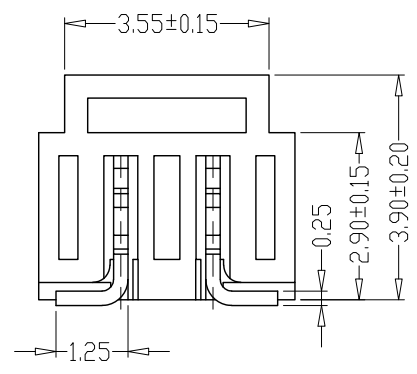
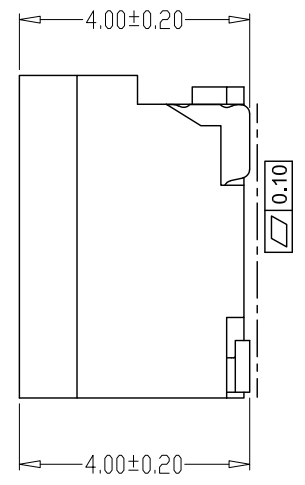
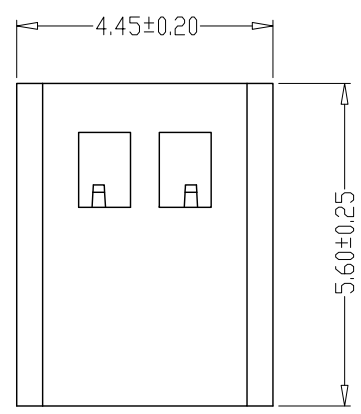

SPECIFICATIONS

- Current Rating: 1A AC, DC
- Voltage Rating: 125V AC, DC
- Temperatuer Range: -25°C~+130°C
- Contact Resistance: 30mΩ Max
- Insulation Resistance: 500MΩ Min
- Withstanding Voltang: 500V AC/minute
- Material  
 Wafer: LCP UL94V-0  
 PIN: Brass Tin-plated  
 Solder tab: Phosphoric bronze Tin-plated

GENEERL TOLERANCE		制图 Mapping	张迎春 2022、09、05	料号 PART NO.	B16001-02AWB	版本 REV.	A
X.±0.25	X.*±2'	审核 Audit	钱岳生 2022、09、06	品名 TITLE	1601卧贴 WAFER SMT TYPE	页次 SHEET	1/1
.X±0.20	.X*±1'	核准 Approved	张名 2022、09、06	客户料号 CUTM. NO.			
.XX±0.15	.XX*±0.5'	单位 Units	MM	比例 SCALE	1:1		
.XXX±0.10	.XXX*±0.5'			<b>乐清市宏一电子有限公司</b> Yueqing HongYi Electronics Co., Ltd			